

TECHNICAL DATA:

The NEW 450 is the next generation of our rotary applied carrier machines for canning production lines. This high-speed unit applies rings at a rate of 300+ cans per minute utilizing a straight-through conveyor design. Quick changeover allows for adjusting to 12oz, 16oz or 19.2oz can format within minutes. It uses the industry leading photodegradable carrier rings offered only by Mumm Products.

- Automatic operation
- 300+ CPM
- 4,6 and 8 pack capable
- 211 Cans 12oz, 16oz or 19.2oz
- 2 wide infeed and discharge
- Straightline feed operation
- Light curtains for easy access
- 15 minute changeover

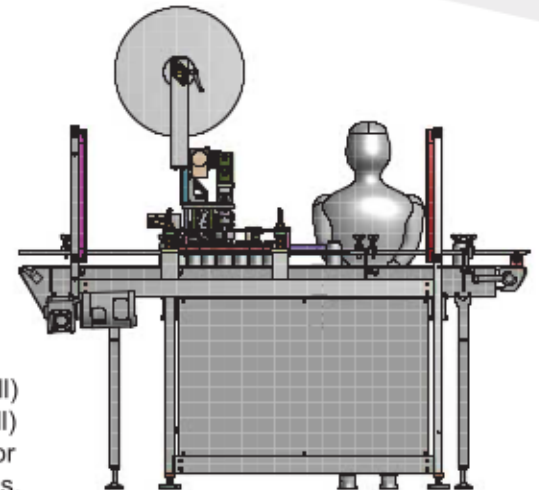
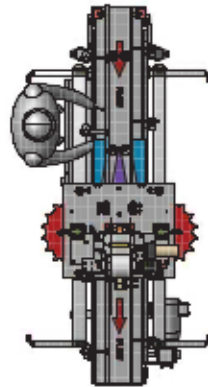

RINGS: PERF-PAK Size..... Style #WC3500 (3500 count roll)
 Style #WX3200 (3200 count roll)

Rings have universal perforations that can be used on 4-packs, 6-packs or 8-packs. Ideal for low cost secure packaging for production line operations.

MACHINE FACTS

Machine Length	96.3"
Machine Width	54"
Machine Access Panels	Light Curtain Guarding for Full Side Access
Height	107" @ 40" Conveyor Ht.
Voltage	240 - VAC
Service Amps	30 @ 240 VAC
Phase	SINGLE
Cycle	60 Hz

Controls	14 AWG - THHN
Water (Gal/Hr)	None Required
Air (SCFM @ 75 PSI)	None Required
Operator Interface	Panasonic GT707
PLC Type	Panasonic FPSigma
Data Collection	N/A
Fault Identification	Yes w/History
Remote Access	N/A
Interlocks	Available